

ICW PRO SLIDE OVERCABINET MONITOR MOUNT WITH DROP POLE INSTALLATION

ICWUSA.com, Inc.

If you have any questions please call Toll Free 1-800-558-4435

► MAXIMUM LOAD CAPACITY: 0-28 LBS. (0-12.7 KG)

STEP 1: MOUNTING PROSLIDE TRACK TO CABINET TOP

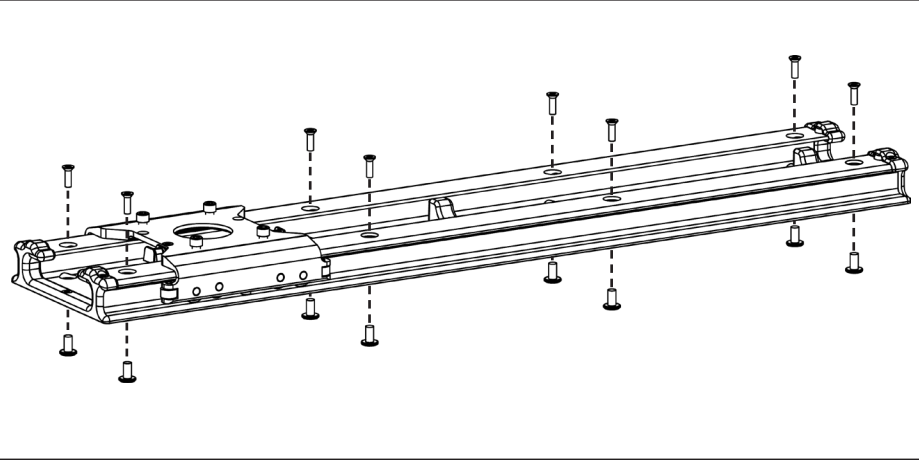

To watch the installation video and follow along, click [here](https://www.youtube.com/watch?v=j4BX2ogJjE) or search: <https://www.youtube.com/watch?v=j4BX2ogJjE>

NOTE: ICW supplies flat head screws and low profile furniture nuts for installing the Pro Slide. 10-24 x 5/8" long screws are supplied and are correct for 3/4" thick mounting surfaces, for surfaces thicker than 3/4", longer screws should be used, minimum 5 turns of thread engagement is necessary. We do not recommend wood screws as this is a load bearing interface, mounting hardware substitutions are at the installer's discretion.

- 1) Installer should verify that the installation surface is flat, level and structurally adequate to support the Pro Slide track/articulating arm assembly.
- 2) Locate the front edge of the track at approximately 9 inches back from cabinet face and locate in desired position, left/right.
- 3) Mark all 8 mounting holes and drill through cabinet top, pilot drill first then drill up to 1/4".
- 4) The flat head screw/furniture nut can install either direction; if an absolutely smooth surface is desired on the inside of the cabinet, then countersink the holes slightly and install the screw from inside the cabinet, otherwise no countersink is necessary.

Installation Video Time Stamp: 0:25

STEP 2: ATTACH ARTICULATING ARM/DROP POLE

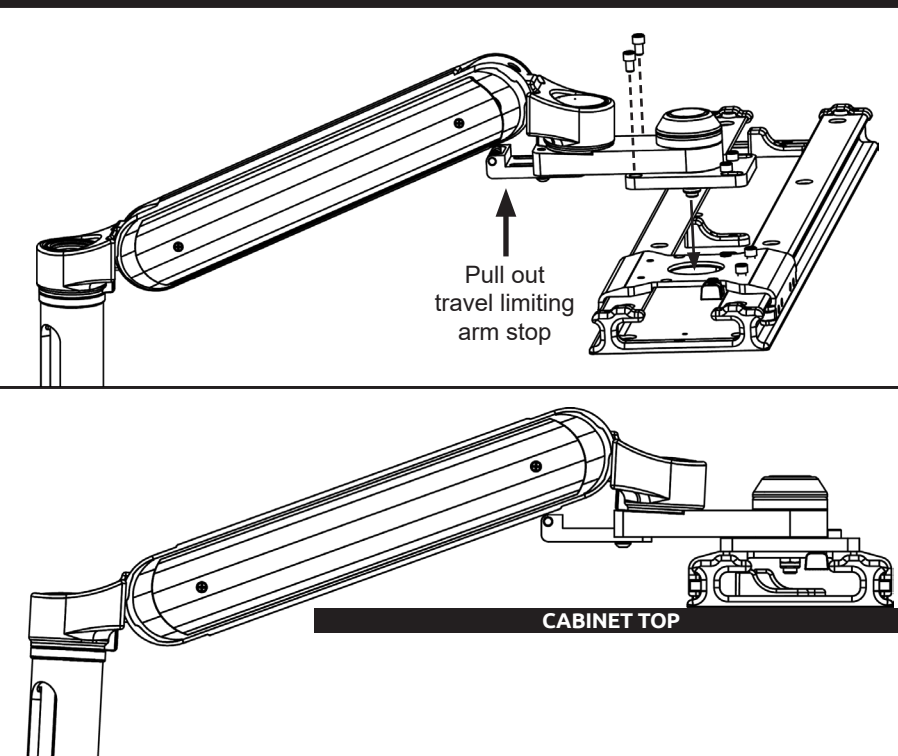

Installation Video Time Stamp: 2:05

- 1) Remove the front two socket head cap screws from the Pro Slide trolley (make sure the rear two are only started into the trolley). Lower the arm adapter plate over the trolley, aligning the keyholes with the two cap screws previously started. Once engaged, slide forward and install the two front cap screws, tighten all 4 with the included 3/16" hex wrench.
- 2) Using a 5/32" hex wrench, adjust travel limiting arm stop to not allow the articulating arm to contact the cabinet top.

PRO SLIDE OVERCABINET MONITOR MOUNT WITH DROP POLE INSTALLATION

STEP 3: ATTACH MONITOR/KEYBOARD, HANDLE, BALL VESA TO DROP POLE

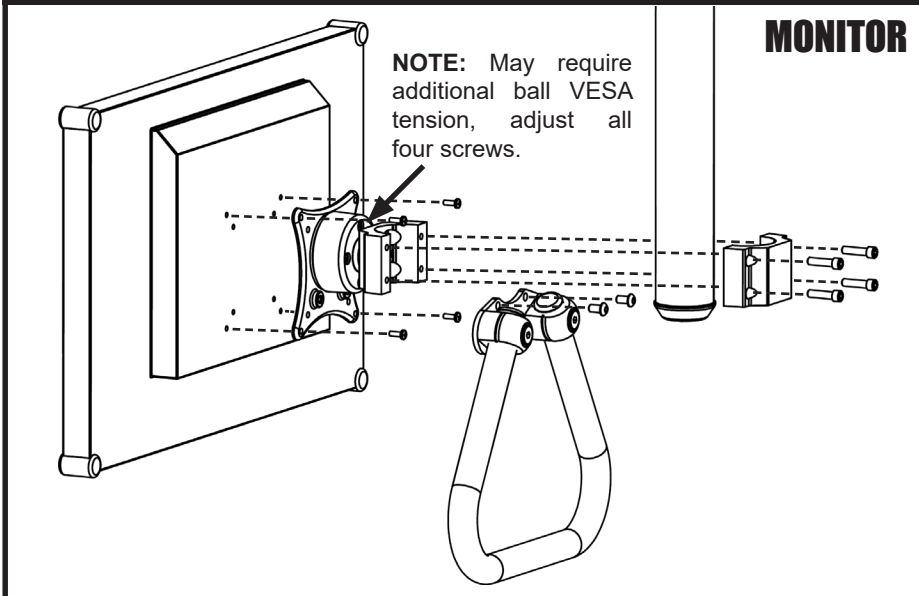

Installation Video Time Stamp: 4:30

- 1)** Attach the ball VESA monitor mount to the monitor using the 4 M4 VESA screws found in the hardware bag, orient the VESA plate so the threaded handle bosses are at the bottom.
- 2)** Attach the handle to the VESA plate using two button head socket cap screws wrapped with the handle and a 5/32" hex wrench.
- 3)** Attach this assembly to the lower end of the drop pole using a 3/16" hex wrench. Make sure that the cable opening is pointing forward (at the monitor).

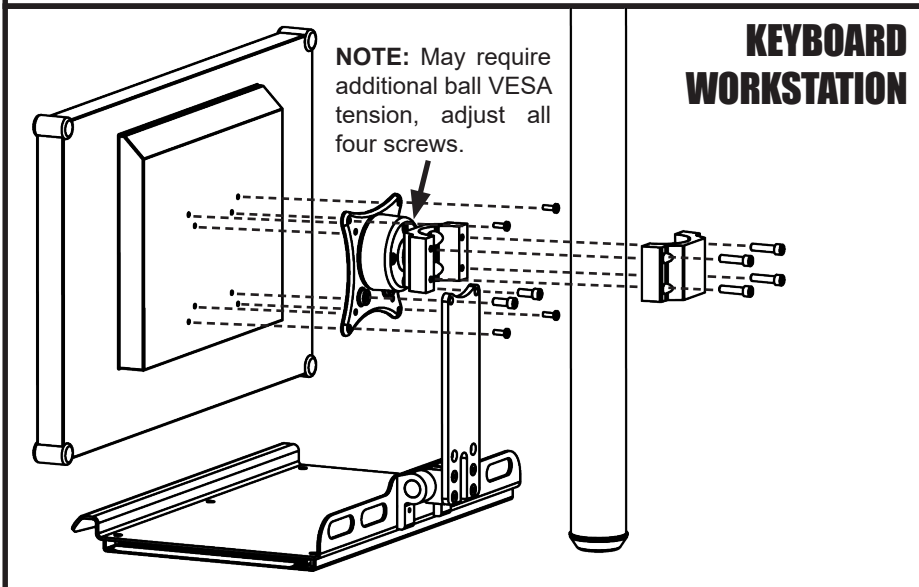

- 1)** Attach the ball VESA monitor mount to the monitor using the 4 M4 VESA screws found in the hardware bag, orient the VESA plate so the threaded handle bosses are at the bottom.
- 2)** Attach the keyboard to the VESA plate using two button head socket cap screws wrapped with the handle and a 3/16" hex wrench.
- 3)** Attach this assembly to the lower end of the drop pole using a 3/16" hex wrench. Make sure that the cable opening is pointing forward (at the monitor).

STEP 4: ADJUST ARTICULATING ARM TENSION

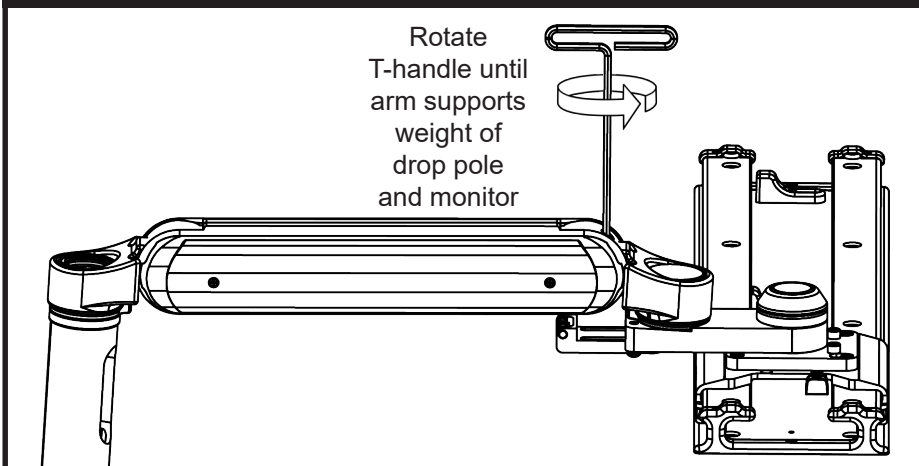

Installation Video Time Stamp: 8:00

- 1)** Raise the articulating arm into horizontal position. Using the 3/16" T-handle hex wrench rotate the adjuster bolt as shown on the arm cover, counter clockwise for more force, clockwise for less.

PRO SLIDE OVERCABINET MONITOR MOUNT WITH DROP POLE INSTALLATION

STEP 5: INTERNAL WIRING AND CABLING

MONITOR

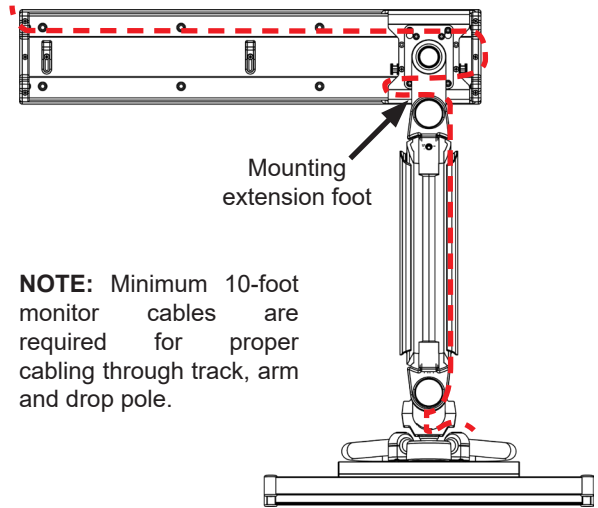
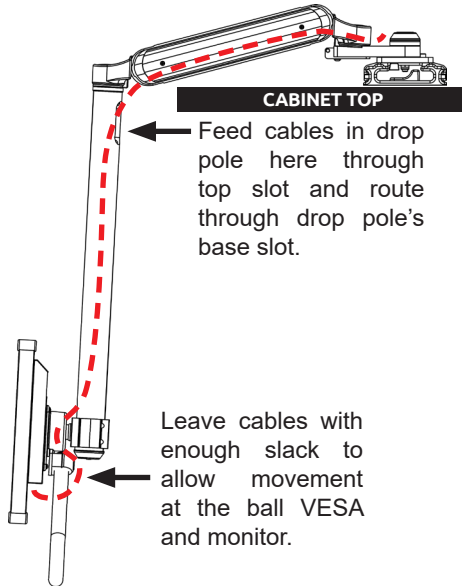

KEYBOARD WORKSTATION

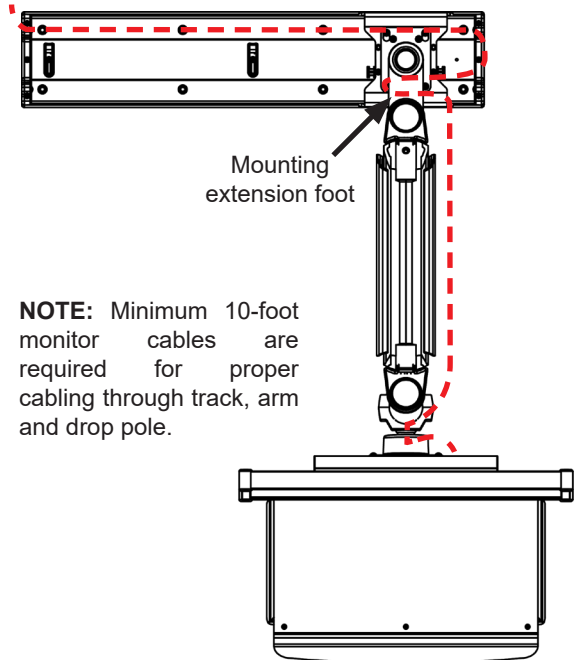
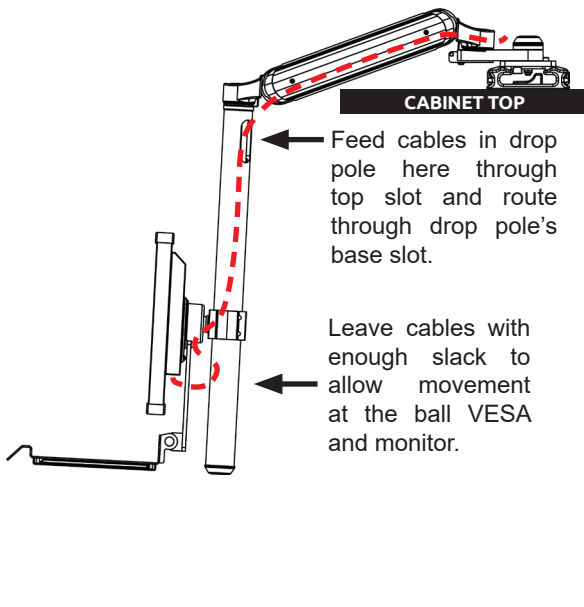

1) Drop the monitor end of the monitor cabling through the drop pole (in the upper slot and out the lower slot) and connect the monitor.

2) Consider which side of the cabinet the cabling will enter the cabinet, if left of the track then route the cables under the right side cover of the articulating arm. Next, pass the cables over the articulating arm extension foot.
[Time Stamp: 8:40]

3) Feed the split loom over the cables making sure that the cables are free and not tangled inside the loom.
[Time Stamp: 11:00]

4) The trolley/arm should be slid to the right end of the track. Loop the cables under the trolley, the cables/loom should cross the track at or just outside of the track end. Use cable ties to attach the cables/loom to the cable tie blocks on the trolley.
[Time Stamp: 12:00]

5) Push the cable/loom clamps against the cable/loom in the center and left end and tighten in place.
[Time Stamp: 14:05]

6) Travel the trolley/arm left to right several times to check for full travel and to ensure no cable binding or rubbing at any pivot point.
[Time Stamp: 14:50]

Installation Video
Time Stamp: 8:35

PRO SLIDE OVERCABINET MONITOR MOUNT WITH DROP POLE INSTALLATION

CLEANING OF THE ICW MOUNTING DEVICE

When cleaning your ICW mounting unit please follow the points below. Proper cleaning of the mounting device will help assure proper function and extend the life of the unit.

1. Any general cleaner is acceptable except degreasers are not recommended near the bearing entrances.
2. Spray cleaner or water on a soft cloth or paper towel and then wipe down the mounts.
3. Do not spray directly at the bearing seams (located at all swivel points) as this could reduce the life of the bearings.

NOTICE: ICWUSA.COM, Inc. provides the appropriate hardware fasteners to match the majority if not all standard monitors and devices. It is the responsibility of the installer / integrator to ensure that the screws and fasteners have the adequate thread engagement. The rule of thumb is that the thread depth is greater than the diameter of the hole or 4 full turns of 360 degrees of thread engagement. It is also the responsibility of the installer / integrator to ensure that they do not damage the monitor or device by using a screw or fastener that is too long for hole and therefore damaging the unit by inserting too far.