



EV65 DUAL MONITOR WALL MOUNT INSTALL

ICWUSA.com, Inc.

If you have any questions please call Toll Free 1-800-558-4435

ATTACH WALL PLATE TO WALL

Locate the stud and mark the top hole, drill 11/64 pilot hole and insert #14 screw and tighten slightly. Using a level, mark the lower hole and drill pilot hole, insert #14 screw and, with the unit level, tighten both screws.

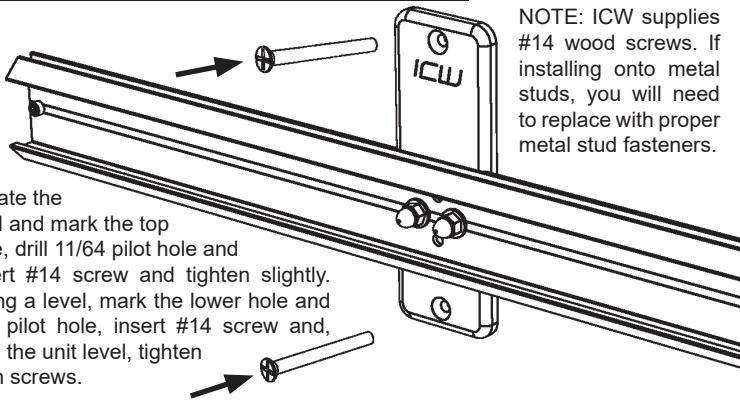

NOTE: ICW supplies #14 wood screws. If installing onto metal studs, you will need to replace with proper metal stud fasteners.

ATTACH VESA TO MONITOR

Attach the monitor mount assembly to the back of your monitor, using the 4mm screws provided.

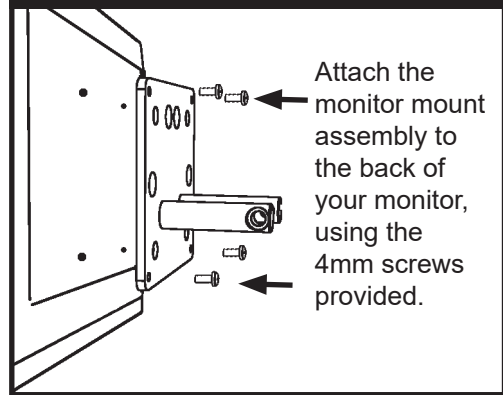

ATTACH VESA TO EV65 JOINT

Insert stubs on VESA plate into holes in the Ergovision joint assembly. Insert 5/16 x 3/4 socket cap screws provided in both sides and tighten. Use the handle under mount to loosen tilt friction and adjust monitor tilt.

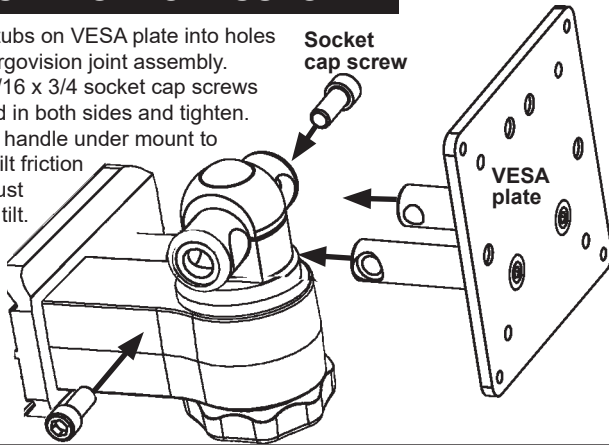

ATTACH EV65 TO TRACK

After loosening slider plate on EV65 by turning chrome handle, slide on to track like shown. Once on, tighten slider in place by using chrome handle. Do this with both monitors.

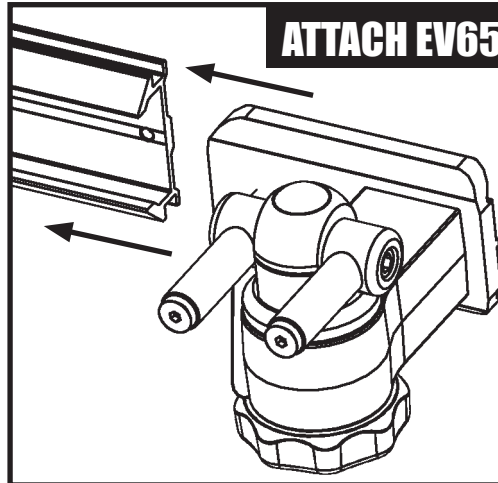

ATTACH TRACK CAP

Once both monitors are on the track, locate track endcaps in hardware bag. These will fit into each end of the track, covering sharp edges. Using two 1 0-32x1 1/4 sockethead cap screws provided, fasten track endcaps to track with 5/32" hex key provided.

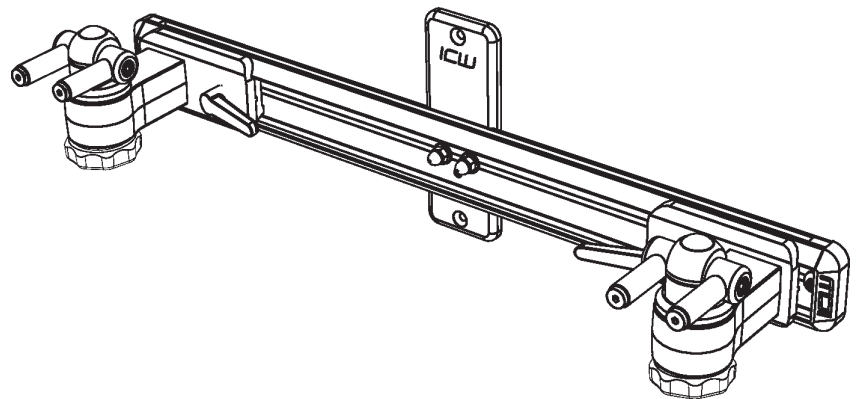
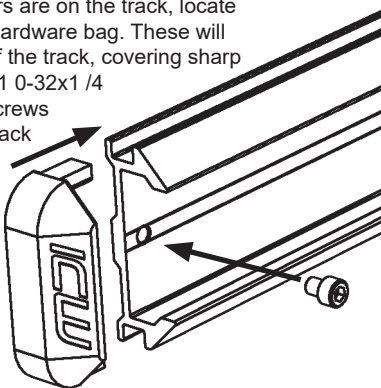

NOTICE: ICWUSA.COM, Inc. provides the appropriate hardware fasteners to match the majority if not all standard monitors and devices. It is the responsibility of the installer / integrator to ensure that the screws and fasteners have the adequate thread engagement. The rule of thumb is that the thread depth is greater than the diameter of the hole or 4 full turns of 360 degrees of thread engagement. It is also the responsibility of the installer / integrator to ensure that they do not damage the monitor or device by using a screw or fastener that is too long for hole and therefore damaging the unit by inserting too far.

CLEANING OF THE ICW MOUNTING DEVICE

When cleaning your ICW mounting unit please follow the points below. Proper cleaning of the mounting device will help assure proper function and extend the life of the unit.

1. Any general cleaner is acceptable except degreasers are not recommended near the bearing entrances.
2. Spray cleaner or water on a soft cloth or paper towel and then wipe down the mounts.
3. Do not spray directly at the bearing seams (located at all swivel points) as this could reduce the life of the bearings.