



EASE
EQUIPMENT ANCHORAGE & SEISMIC ENGINEERING
 5877 Pine Ave, Ste. 210
 Chino Hills, CA. 91709
 Phn: (909) 606-7622 Fax: (866) 801-4975

Office of Statewide Health Planning and Development
ANCHORAGE PRE-APPROVAL

OPA-2085-10

THIS PRE- APPROVAL CONFORMS TO THE 2010 CALIFORNIA BUILDING CODE

Equipment Manufacturer: ICW USA INC.

Equipment Type: Double Arm Elite

GENERAL NOTES

1. FORCES PER ASCE 7-05 SECTION 13.3.1, EQUATIONS 13.3-1, 13.3-2 & 13.3-3, WHERE $S_{Ds} = 2.0$, $a_p = 2.5$, $I_p = 1.5$ & $R_p = 2.5$, $z/h \leq 1.0$
2. THIS PRE-APPROVAL CONFORMS TO THE 2010 CALIFORNIA BUILDING CODE.
3. THE DETAILS IN THIS PRE-APPROVAL MAY BE USED AT ANY HEIGHT AND AT ANY LOCATION IN THE STATE OF CALIFORNIA, WHERE SDS IS NOT GREATER THAN 2.0.
4. ALL ANCHOR FORCES SHOWN ON THE DRAWINGS ARE FACTORED LOADS THAT SHALL BE USED FOR STRENGTH DESIGN.
5. SHEET METAL SCREWS SHALL BE TEKS SCREWS BY ITW BUILDEX (ICC ESR-1976).
6. THIS PRE-APPROVAL COVERS ONLY THE ANCHORAGE OF THE UNIT TO THE HOSPITAL BUILDING'S STRUCTURE

RESPONSIBILITIES OF THE STRUCTURAL ENGINEER OF RECORD OF THE BUILDING

7. DESIGN BACKING BARS, STUDS, ETC. WHICH THE UNITS ARE ATTACHED TO AS NOTED ON THE DRAWINGS.
 THE SEOR SHALL ALSO VERIFY THE ADEQUACY OF THE STRUCTURES (SUCH AS WALLS AND FLOORS) WHICH SUPPORT THE UNITS FOR THE LOADS IMPOSED ON THEM BY THE UNITS AS WELL AS ALL OTHER LOADS.
8. PROVIDE SUPPORTING STRUCTURE REQUIRED TO SUPPORT WEIGHTS AND FORCES SHOWN, IN ADDITION TO ALL OTHER LOADS.
9. VERIFY THAT THE INSTALLATION IS IN CONFORMANCE WITH THE 2010 CBC AND WITH THE DETAILS SHOWN IN THIS PRE-APPROVAL.
 VERIFY THAT THE ACTUAL EQUIPMENT'S WEIGHT, CG LOCATION, ANCHOR LOCATIONS, ANCHOR DETAILS AND THE MATERIAL AND GAGE OF THE UNIT WHERE ATTACHMENTS ARE MADE AGREE WITH THE INFORMATION SHOWN ON THE PRE-APPROVAL DOCUMENTS.
10. VERIFY THAT THE COMBINATION OF S_{Ds} & z/h RESULT IN SEISMIC FORCES (E_h , E_v) THAT ARE NOT GREATER THAN THE VALUES ON THE DETAILS.



ICW USA INC.

DOUBLE ARM ELITE

DES. **J. ROBERSON**

JOB NO. **11-1143**

DATE **11/13/12**

SHEET

2

OF **7** SHEETS

SEISMIC ANCHORAGE

WALL MOUNTED

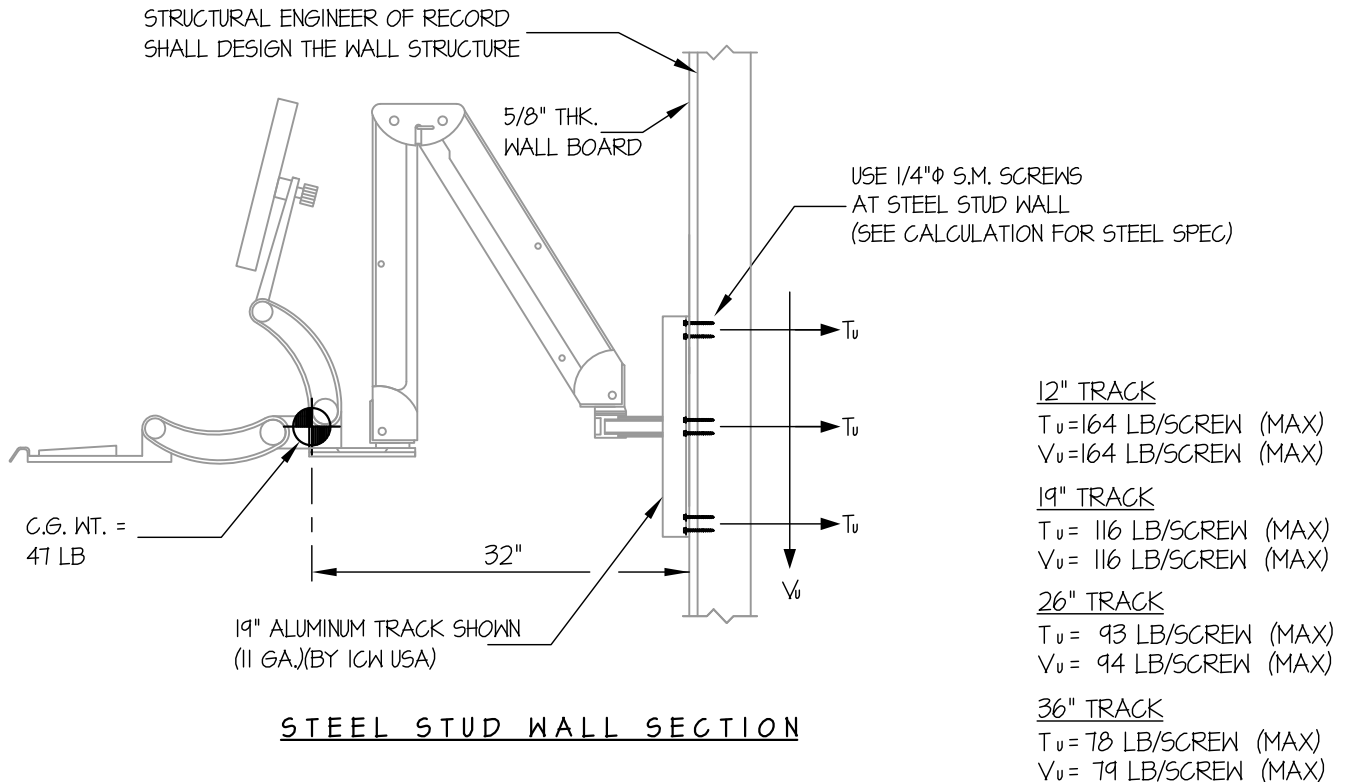

STEEL STUD WALL SECTION

NOTES:

1. ANCHORAGE DESIGN PER 2010 CALIFORNIA BUILDING CODE AND ASCE 7-05. STRENGTH DESIGN IS USED.

HORIZONTAL FORCE (E_H) = $3.60 W_p$ ($S_{DS} = 2.00, a_p = 2.5, I_p = 1.5, R_p = 2.5, z/h \leq 1.0$)

VERTICAL FORCE (E_v) = $0.40 W_p$

2. CENTER OF GRAVITY (C.G.) WEIGHT IS A MAXIMUM. THIS PRE-APPROVAL ENCOMPASSES ALL WEIGHTS UP TO THE MAXIMUM WEIGHT SHOWN.
3. STRUCTURAL ENGINEER OF RECORD FOR THE BUILDING SHALL PROVIDE SUPPORT STRUCTURE DESIGNED TO SUPPORT WEIGHTS AND FORCES SHOWN, IN ADDITION TO ALL OTHER LOADS.
4. SEE GENERAL NOTES: SHEET 1



A P P R O V E D
 Fixed Equipment Anchorage
 Office of Statewide Health Planning and Development

OPA-2085-10

Pre-approval Program Manager:
 Anthony R. Pike
 (916) 440-8478

Bill Staehlin

Reviewed By: **BILL STAEHLIN** 11/13/12

ICW USA INC.

DOUBLE ARM ELITE

DES. **J. ROBERSON**

JOB NO. **11-1143**

DATE **11/13/12**

SHEET

3

OF **7** SHEETS

SEISMIC ANCHORAGE

12" TRACK

WALL MOUNTED

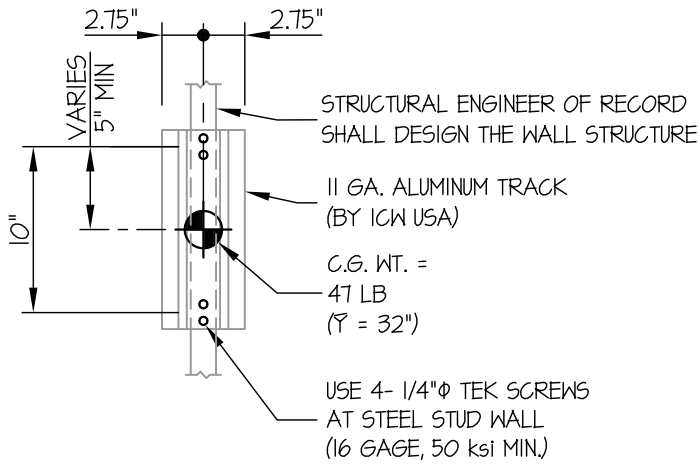

ELEVATION AT WALL PLATE

2 x STUDS OR 4 x BLKG
 (DOUGLAS-FIR LARCH
 NUMBER 2 MIN.)
 (DESIGNED BY STRUCTURAL
 ENGINEER OF RECORD)

USE 4- 1/4" ϕ X 4"
 LAG SCREWS TO
 WOOD STUD OR BLKG.
 (PRE-DRILL HOLES
 TO 70% SHANK DIAMETER)

5/8" THK.
 WALL BOARD

WOOD STUD WALL SECTION



APPROVED
 Fixed Equipment Anchorage
 Office of Statewide Health Planning and Development

OPA-2085-10
 Pre-approval Program Manager:
 Anthony R. Pike
 (916) 440-8478

Bill Staehlin
 Reviewed By: **BILL STAEHLIN** 11/13/12

ICW USA INC.

DOUBLE ARM ELITE

DES. **J. ROBERSON**

JOB NO. **11-1143**

DATE **11/13/12**

SHEET

4

OF **7** SHEETS

SEISMIC ANCHORAGE

19" TRACK

WALL MOUNTED

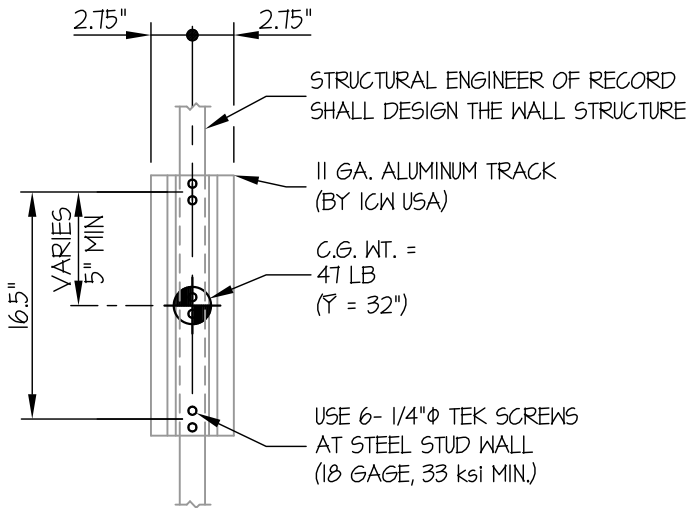

ELEVATION AT WALL PLATE

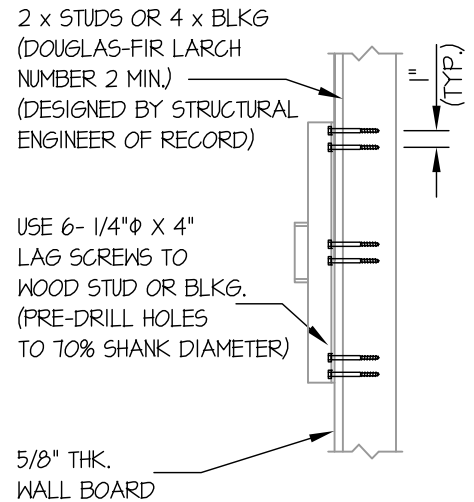

WOOD STUD WALL SECTION



A P P R O V E D
 Fixed Equipment Anchorage
 Office of Statewide Health Planning and Development

OPA-2085-10

Pre-approval Program Manager:
 Anthony R. Pike
 (916) 440-8478



Bill Staehlin

Reviewed By: **BILL STAEHLIN** 11/13/12

ICW USA INC.

DOUBLE ARM ELITE

DES. **J. ROBERSON**

JOB NO. **11-1143**

DATE **11/13/12**

SHEET

5

OF **7** SHEETS

SEISMIC ANCHORAGE

26" TRACK

WALL MOUNTED

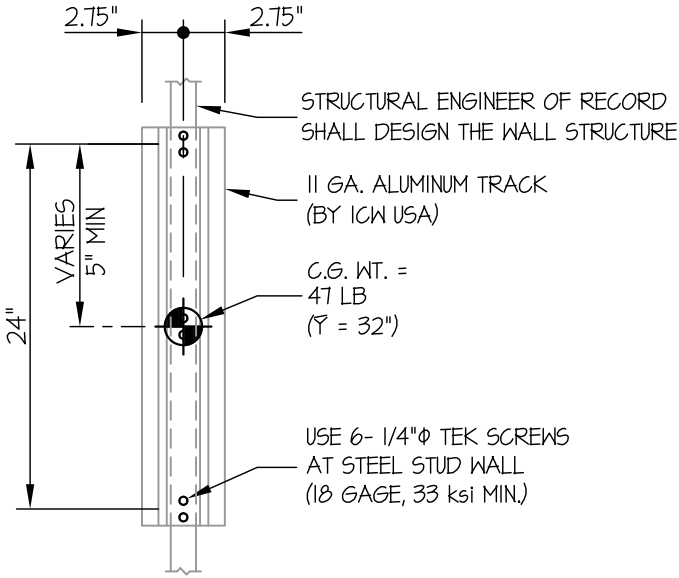

ELEVATION AT WALL PLATE

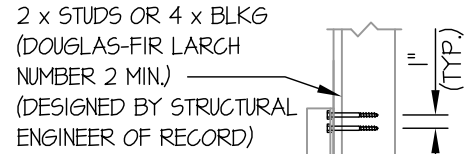

USE 6- 1/4"φ X 4" LAG SCREWS TO WOOD STUD OR BLKG. (PRE-DRILL HOLES TO 70% SHANK DIAMETER)

5/8" THK. WALL BOARD

WOOD STUD WALL SECTION



APPROVED
 Fixed Equipment Anchorage
 Office of Statewide Health Planning and Development

OPA-2085-10

Pre-approval Program Manager:
 Anthony R. Pike
 (916) 440-8478

Bill Staehlin

Reviewed By: **BILL STAEHLIN** 11/13/12

ICW USA INC.

DOUBLE ARM ELITE

DES. **J. ROBERSON**

JOB NO. **11-1143**

DATE **11/13/12**

SHEET

6

OF **7** SHEETS

SEISMIC ANCHORAGE

36" TRACK

WALL MOUNTED

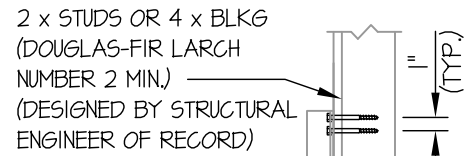
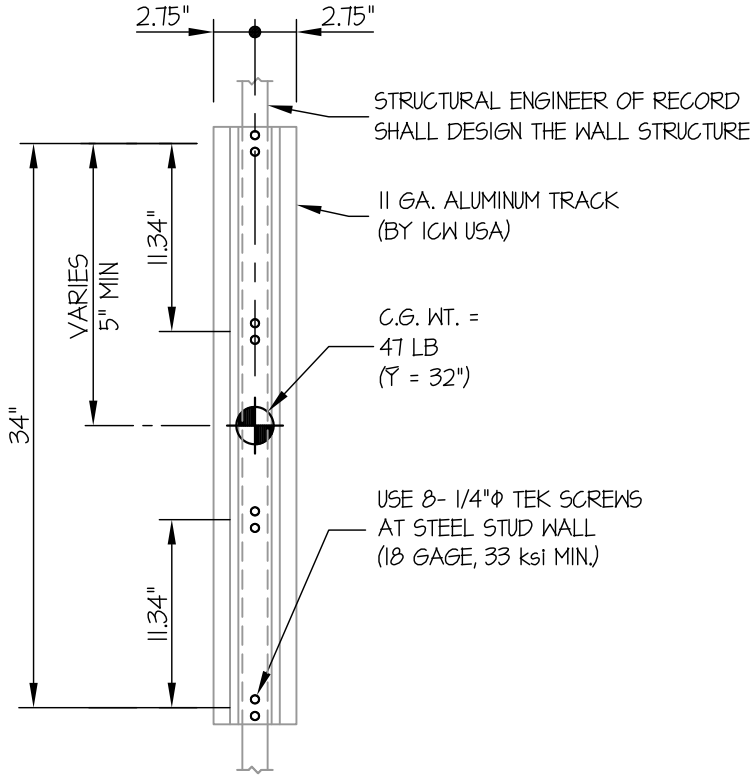

USE 8- 1/4"φ X 4" LAG SCREWS TO WOOD STUD OR BLKG. (PRE-DRILL HOLES TO 70% SHANK DIAMETER)

5/8" THK. WALL BOARD

ELEVATION AT WALL PLATE

WOOD STUD WALL SECTION



APPROVED
 Fixed Equipment Anchorage
 Office of Statewide Health Planning and Development

OPA-2085-10

Pre-approval Program Manager:
 Anthony R. Pike
 (916) 440-8478

Bill Staehlin

Reviewed By: **BILL STAEHLIN** 11/13/12

ICW USA INC.

DOUBLE ARM ELITE

DES. **J. ROBERSON**

JOB NO. **11-1143**

DATE **11/13/12**

SHEET

7

OF **7** SHEETS

SEISMIC ANCHORAGE

50" TRACK

WALL MOUNTED

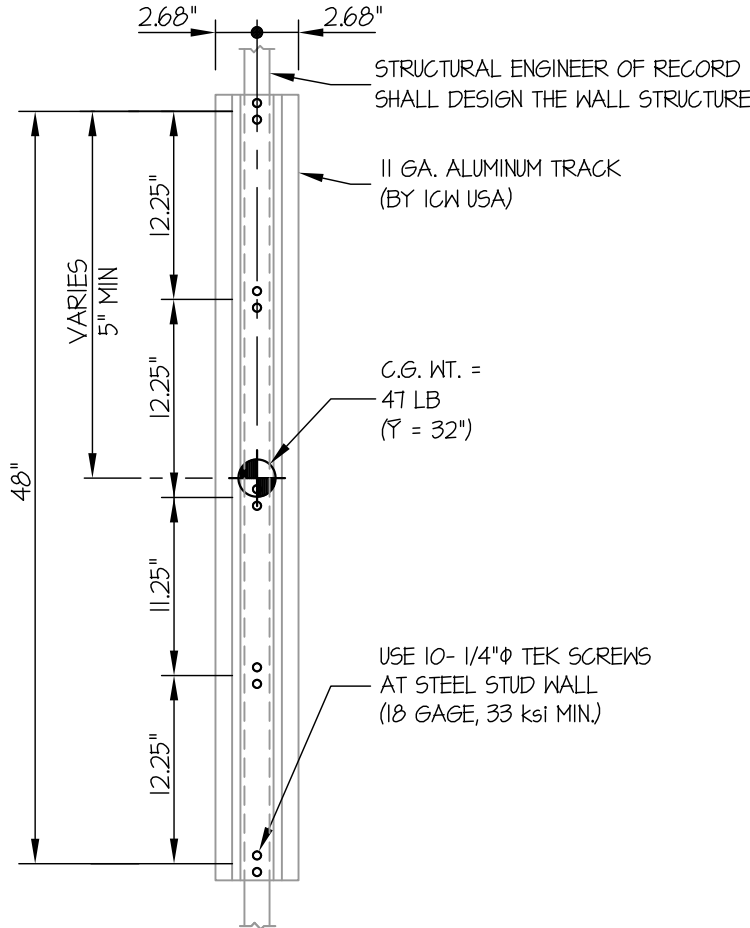

ELEVATION AT WALL PLATE

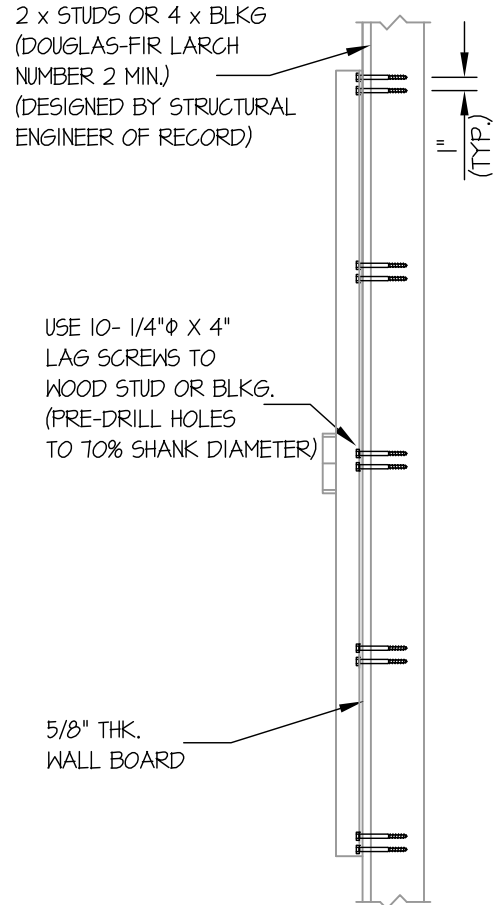

WOOD STUD WALL SECTION



A P P R O V E D
 Fixed Equipment Anchorage
 Office of Statewide Health Planning and Development

OPA-2085-10

Pre-approval Program Manager:
 Anthony R. Pike
 (916) 440-8478

Bill Staehlin

Reviewed By: **BILL STAEHLIN** 11/13/12