

# Ultra 110 Series Mount



Model Number as shown:  
UL110-W2-KUF-A5-QG

**ICW**

# Ultra 110 Series Mount

## DESCRIPTION:

The Ultra 110 compact LCD arm is our professional compact LCD and keyboard mount. Whether mounting to a desk, pole or wall, this mount keeps your monitor close to your mounting surface while still giving you a wide range of adjustment.

## FEATURES:

- Compact monitor mount
- Fold-up keyboard tray
- Slide-out mouse tray

## OPTIONS:

- Flat, ergonomic or mini keyboard tray
- 11" arm extension

## SPECIFICATIONS:

Finish:	Gray or black
Weight capacity:	18 lbs (8.16 kg)
Vert. adjustment range:	6"
Screen swivel:	360°
Screen tilt:	180°
VESA Interface:	75mm and 100mm

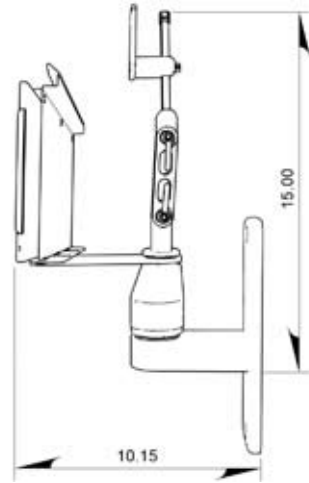

SIDE ELEVATION folded

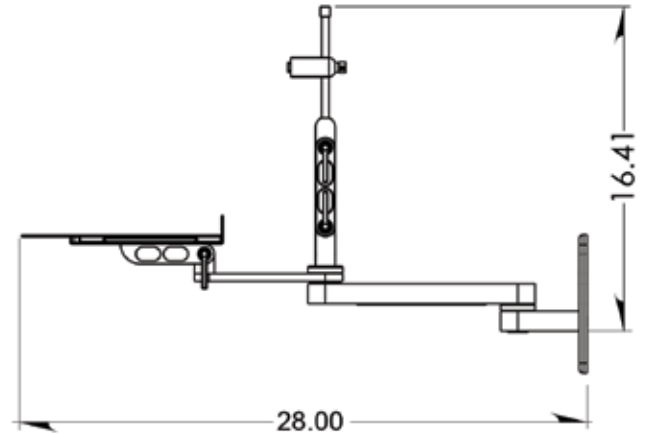

SIDE ELEVATION extended

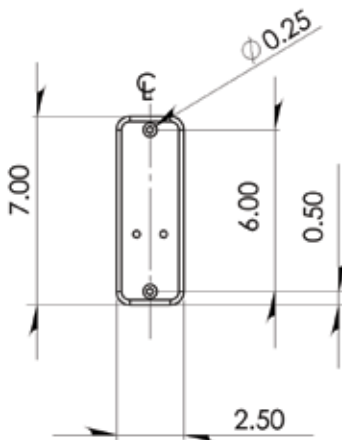

WALL PLATE

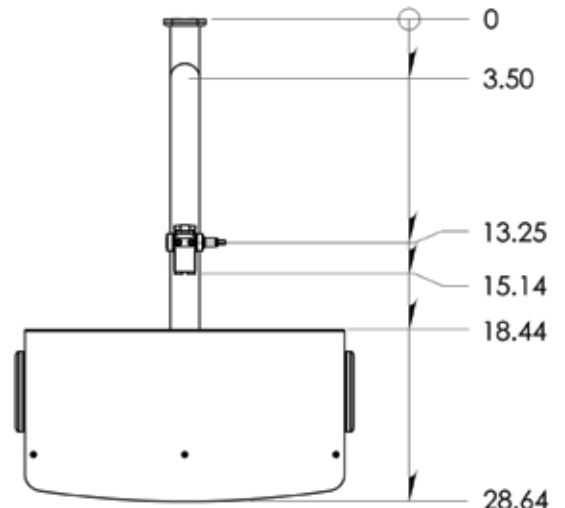

TOP VIEW

